



SINGLEPOINT AQUATIC HEATING PACKAGE

PRE-PACKAGED HEAT TRANSFER SKID FOR AQUATIC HEATING APPLICATIONS



MODEL NUMBER	SPECIFICATION			DIMENSIONS			
	Design Aquatic Flow (GPM)	Aquatic PSID	Max BTU Output (Heating)	Length (L)	Width (W)	Max. Height (H)	Aquatic Connection Size
DH-SAHP-110	120	5	104 500	48"	24"	67"	2"
DH-SAHP-155	180	5	147 250	48"	24"	67"	3"
DH-SAHP-199	180	5	189 050	48"	24"	67"	3"
DH-SAHP-285	180	5	270 750	48"	24"	67"	3"
DH-SAHP-400	360	5	380 000	72"	36"	67"	3"
DH-SAHP-500	360	5	475 000	72"	36"	67"	3"

* BTU Output based on 70°F incoming aquatic water at design aquatic flow

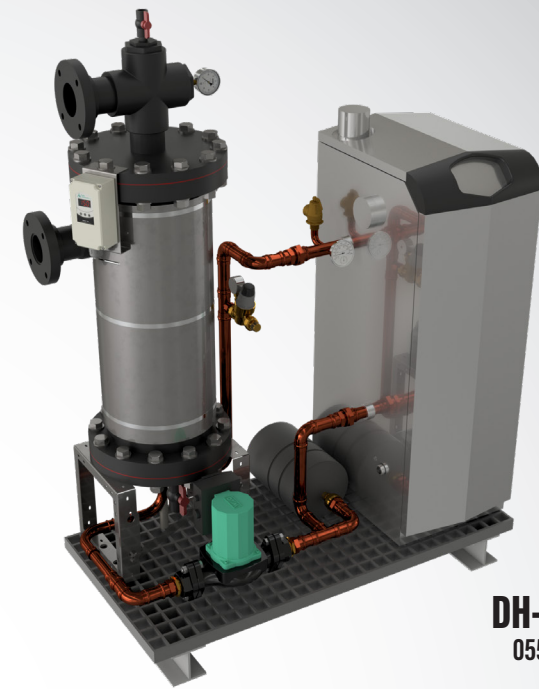

DH-SAHP
055 - 285

NOTES:

- Sch80 PVC HEAT EXCHANGER SHELL WITH TITANIUM COIL FOR MARINE APPLICATIONS
- PACKAGE ARRIVES PREWIRED AND ASSEMBLED FOR EASY INSTALLATION
- 220V/1ph POWER REQUIRED
- FLOW AND TEMPERATURE SAFETY LIMITS
- ALL 316SS HARDWARE ON PHE AND SKID
- MODULATING, HIGH EFFICIENCY BOILER FOR ACCURATE TEMPERATURE CONTROL
- EASILY CLEANABLE HEAT EXCHANGER
- NATURAL GAS OR PROPANE REQUIRED
- THERMOWELL AND FLOW SWITCH SHIPPED LOOSE FOR FIELD INSTALLATION

OPTIONS:

- OUTDOOR PACKAGE
- Sch80 CPVC SHELL

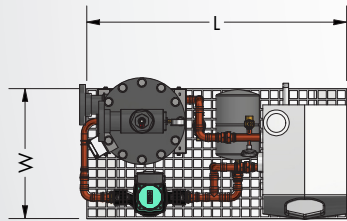

PLAN VIEW 055 - 285

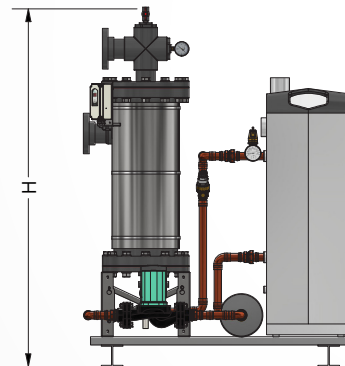

SIDE VIEW 055 - 285

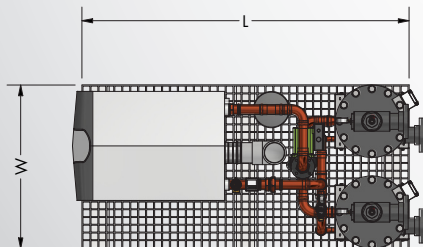

PLAN VIEW 400-500

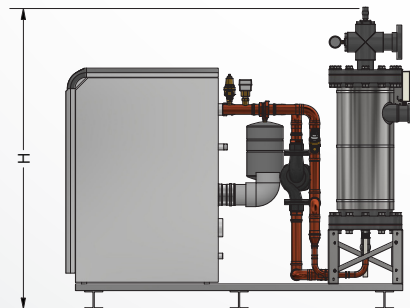

SIDE VIEW 400-500

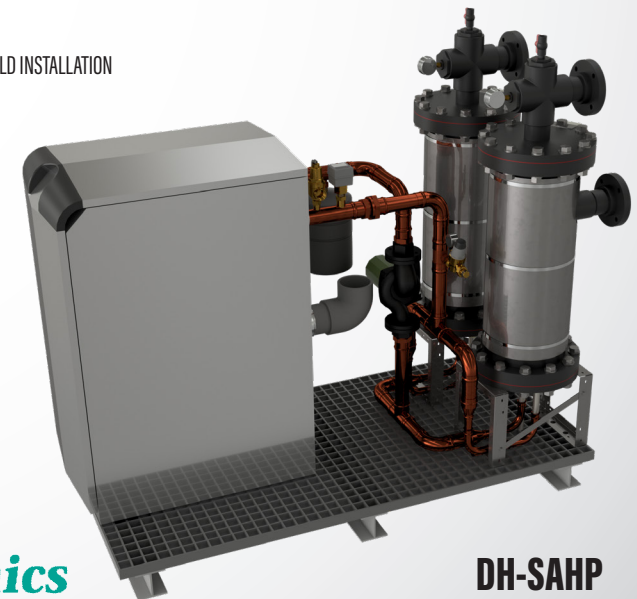

DH-SAHP
400 - 500

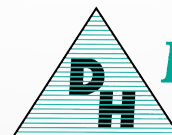

Delta Hydronics

9100 Bolton Ave., Hudson, FL, 34667 (727) 861-2421 - info@deltahydro.com